

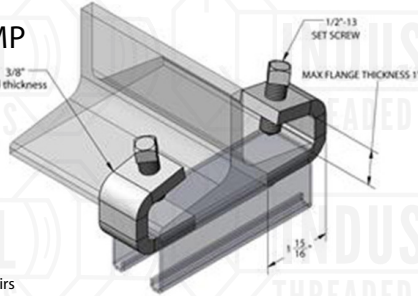

9083BC

STRUT BEAM CLAMP HEAVY DUTY

3/8" THICK



Max flange thickness 1"
1/2"-13 set screw

Design load 1000 lbs when used in pairs

Material: 1/4"
Finish: Electro-Galvanized
Hole Dim: 9/16"
Wt. Each (lbs): .93

9084BC

STRUT "Z" BEAM CLAMP HEAVY DUTY

3/8" THICK

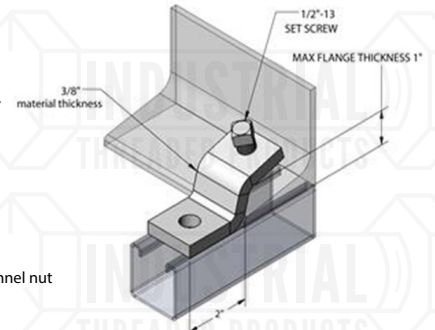

Max Flange thickness 1"
Clamp requires 1/2"-13 HCS and 1/2" channel nut
1/2"-13 set screw
Design load 1100 lbs when used in pairs

Material: 1/4"
Finish: Electro-Galvanized
Hole Dim: 9/16"
Wt. Each (lbs): .64

9085BC

STRUT BEAM CLAMP WINDOW TYPE FOR 1-5/8" STRUT

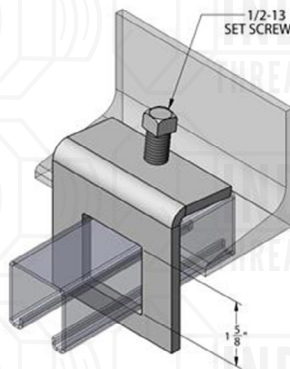

1/2"-13 set screw

Design load 950 lbs when used in pairs

Material: 1/4"
Finish: Electro-Galvanized
Hole Dim: 9/16"
Wt. Each (lbs): 1.06

9086BC

STRUT U-BOLT BEAM CLAMP FOR 13/16" AND 1-5/8" STRUT

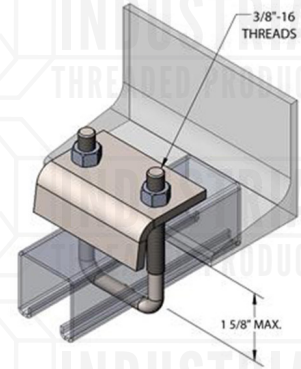

3/8" - 16 threads

Design load 1200 lbs when used in pairs

Material: 1/4"
Finish: Electro-Galvanized
Hole Dim: 9/16"
Wt. Each (lbs): .84

9087BC

STRUT U-BOLT BEAM CLAMP FOR 2-7/16" AND 3-1/4" STRUT

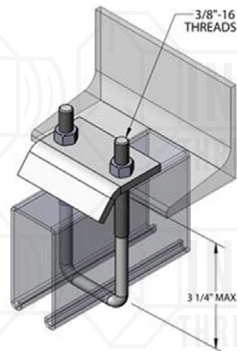

3/8" - 16 threads

Design load 1200 lbs when used in pairs

Material: 1/4"
Finish: Electro-Galvanized
Hole Dim: 9/16"
Wt. Each (lbs): .93

9088PB

POST BASE FOR 1-5/8" X 1-5/8" STRUT 5-1/8" X 5-1/8" BASE

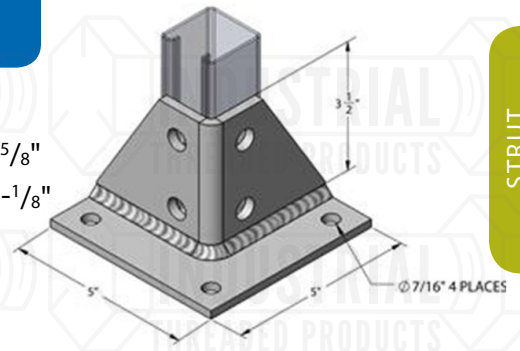

Material: 1/4"
Finish: Electro-Galvanized, SST 316 & 304
Hole Dim: 9/16"
Wt. Each (lbs): 2.88