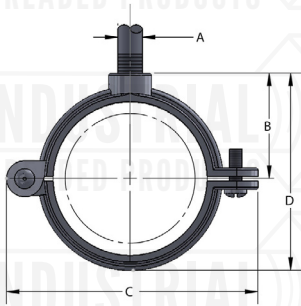



**FIG. 41H**  
**SPLIT RING EXTENSION HANGER, HINGE DESIGN**



**Material:** Malleable iron.  
**Finish:** Plain, electro-galvanized.  
**Service:** Designed for suspension of non-insulated stationary pipe lines horizontally or vertically.  
**Approvals:** Complies with Federal Specification WWH-171-E. (Type# 25), A-A-1192A (Type# 12), Manufacturers' Standardization Society SP-58 and MSS SP-69 (Type# 12).  
**Ordering:** Specify pipe size, figure number and finish.

PIPE SIZE	PIPE OD	SCREW	A	B	C	D	WEIGHT EACH (lbs)	MAX REC LOAD (lbs)
3/8	0.675	10-24	3/8-16	11/16	1 13/16	1 3/16	0.084	180
1/2	0.840		3/8-16	3/4	2 1/8	1 3/16	0.098	
3/4	1.050		3/8-16	7/8	2 1/2	1 9/16	0.112	
1	1.315		3/8-16	1 1/8	2 3/4	2	0.147	
1 1/4	1.660		3/8-16	1 5/16	3 3/16	2 3/8	0.181	
1 1/2	1.900		3/8-16	1 7/16	3 3/8	2 5/8	0.214	
2	2.375		3/8-16	1 5/8	3 15/16	3 1/16	0.299	
2 1/2	2.875	1/4	1/2-13	2 1/8	5 3/16	3 13/16	0.583	300
3	3.500		1/2-13	2 1/2	5 11/16	4 5/8	0.713	
4	4.500		1/2-13	2 7/8	6 3/4	5 9/16	1.019	

Project Information		Approval Stamp
Project:		Notes:
Address:	Contractor:	
Date:	Engineer:	
Approved <input type="checkbox"/>	Approved as Noted <input type="checkbox"/>	Not Approved <input type="checkbox"/>