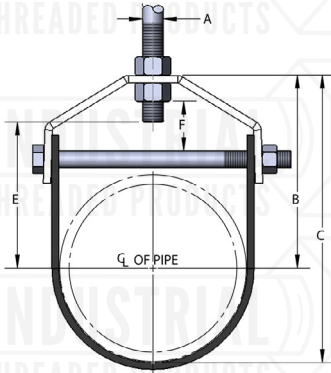

**FIG. 110PC  
PLASTIC COATED CLEVIS HANGER**



**Material:** Carbon steel.

**Finish:** Top of hanger as well as nut and cross bolt are electro-galvanized and bottom of hanger is plastic coated.

**Service:** Designed for the suspension of non-insulated stationary pipe lines in light duty applications. Plastic coating prevents pipe from coming in contact with hanger; resulting in noise and vibration reduction as well as the prevention of electrolysis between pipe and hanger.

**Approvals:** Complies with Federal Specification WW-H-171-E (Type# 12) and Manufacturers' Standardization Society MSS SP-58 and SP-69 (Type# 1).

**Ordering:** Specify pipe size and figure number.

**Notes:** Available domestic

PIPE SIZE	PIPE OD	MATERIAL SIZE		BOLT	A	B	C	E	F	WEIGHT EACH (lbs)	MAX REC LOAD (lbs)
		TOP	BOTTOM								
1/2	0.840	18ga x 7/8	18ga x 7/8	1/4	3/8	1 3/4	2 1/8	1	1/2	0.12	250
3/4	1.050	18ga x 7/8	18ga x 7/8		3/8	1 13/16	2 5/16	1 1/16	1/2	0.12	
1	1.315	18ga x 7/8	18ga x 7/8		3/8	2 1/8	2 3/4	1 5/16	3/4	0.12	
1 1/4	1.660	18ga x 7/8	18ga x 7/8		3/8	2 1/2	3 1/4	1 3/4	1 5/16	0.18	
1 1/2	1.900	14ga x 7/8	16ga x 7/8		3/8	2 13/16	3 13/16	2 1/16	1 1/8	0.24	
2	2.375	14ga x 7/8	16ga x 7/8		3/8	3 5/16	4 1/2	2 9/16	1 1/4	0.26	
2 1/2	2.875	12ga x 1 3/16	14ga x 1 3/16		1/2	4 1/2	5 5/16	3 7/16	2 1/16	0.58	
3	3.500	12ga x 1 3/16	14ga x 1 3/16	5/16	1/2	4 13/16	6 9/16	3 3/4	1 7/8	0.66	350
3 1/2	4.000	11ga x 1 3/16	14ga x 1 3/16		1/2	5 15/16	7 7/8	4 7/8	2 5/8	0.82	
4	4.500	11ga x 1 3/16	14ga x 1 3/16	3/8	1/2	6 1/16	8 5/16	5	2 3/8	0.94	400
5	5.563	4ga x 1 1/4	8ga x 1 1/4	1/2	5/8	5 11/16	8 7/16	4 5/16	1 7/16	2.04	1430
6	6.625	3ga x 1 1/2	8ga x 1 1/2		3/4	6 13/16	10 1/8	5 3/16	1 3/4	2.80	1940
7	7.625	3ga x 1 1/2	8ga x 1 1/2		3/4	7 13/16	11 5/8	6 3/16	2	3.24	2000
8	8.625	3ga x 1 3/4	8ga x 1 3/4	5/8	7/8	8 1/16	12 7/16	6 1/4	1 7/8	4.46	
10	10.750	3/8 x 1 3/4	3ga x 1 3/4	3/4	7/8	10	15 7/16	8	2 1/4	8.06	3600
12	12.750	3/8 x 2	3ga x 2		7/8	11 9/16	18	9 9/16	2 13/16	10.34	3800

Project Information		Approval Stamp
Project:		Notes:
Address:	Contractor:	
Date:	Engineer:	
Approved <input type="checkbox"/>	Approved as Noted <input type="checkbox"/>	Not Approved <input type="checkbox"/>